

Applications in the Petrol Refinery

Case histories with DP cell problems

(www.distillationsgroup.com).

Prepared for *Hydrocarbon Online: March 2001*

“Differential pressure (DP) cells are the most often used level measuring device in the process industries. Differential pressure cells measure the pressure difference between two points and send a differential pressure reading to the plant control system. Typically, DP cells are rated in inches of water equivalent. Standard ranges include 0 to 20, 0 to 50, 0 to 100, 0 to 200, and 0 to 500 inches of water differential pressure.

The control system converts the DP cell reading into a liquid level based on an assumed specific gravity inside the vessel. Levels based on DP cells can err for different reasons. Previous columns have covered many reasons DP cells or sight glasses can give false readings. This column covers some case histories of specific DP cell problems.”

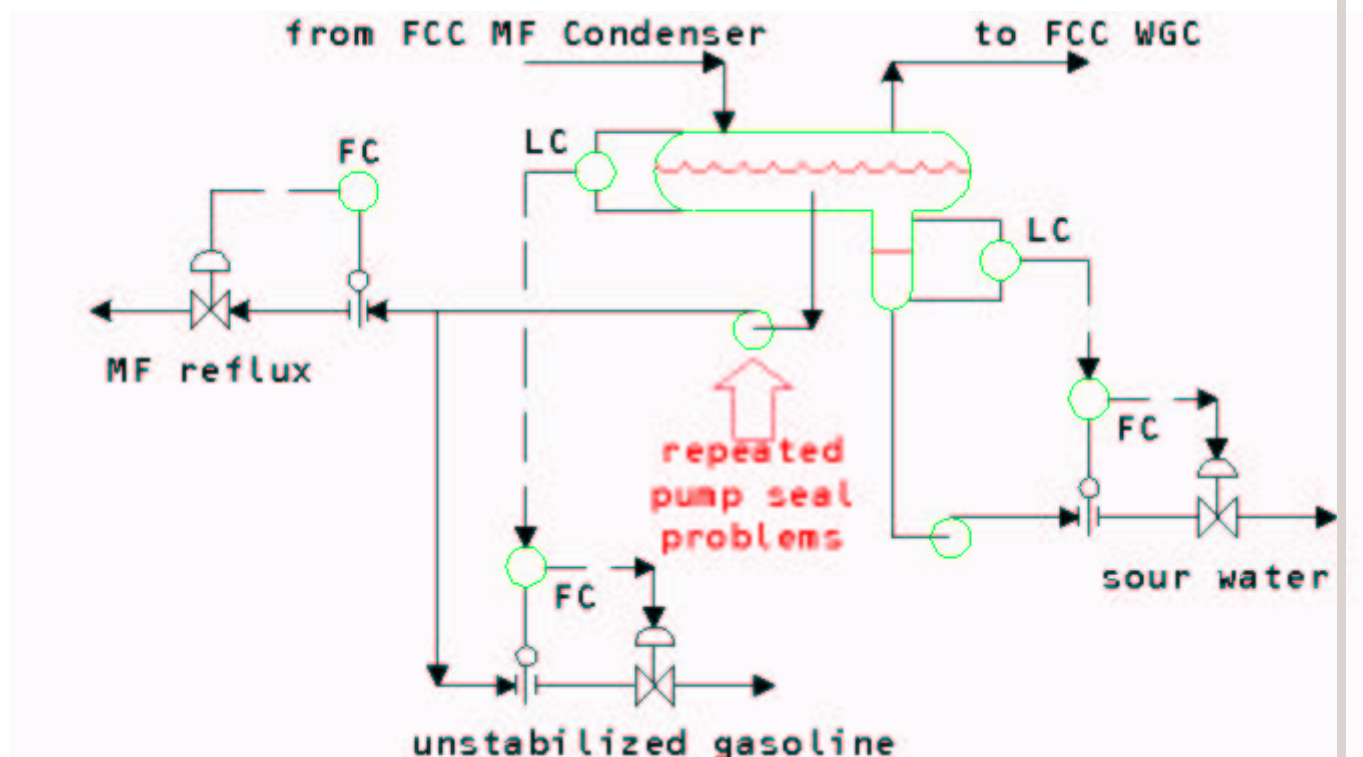

Figure 6
Pump seal failures common

“Over time, the new operation was accepted as normal. However, the situation continued to nag on some of the operators involved. While on site for operator

training, the author was asked about this problem and a new troubleshooting effort started. Field data was gathered and compared to operating data. One suspicious observation was immediately obvious. The water level measured in the drum never seemed to vary. The connections to the water level instrument were blown out and the instrument placed back in service. The measured water level immediately jumped from 54% of range to 100%. The water level was above the upper water level tap. A plug in the line to the water level instrument had blocked the instrument at 54% of range (Figure 7).”

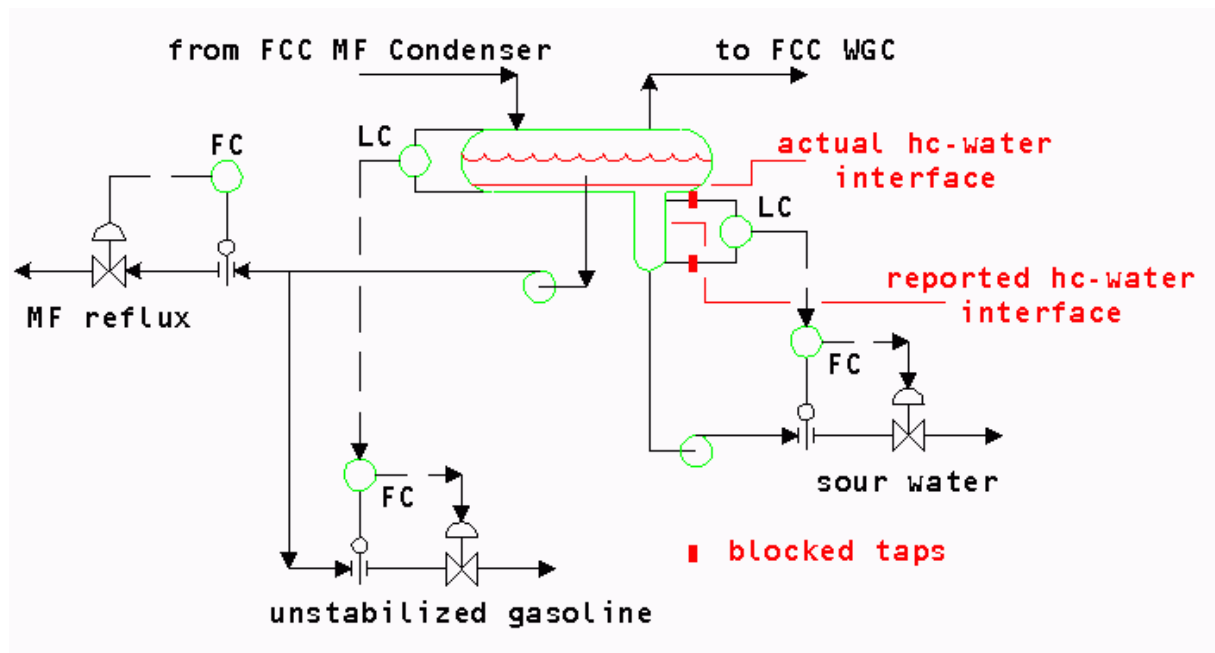

Figure 7
Blocked level taps

Problems with separating layer measuring cannot be:

The measurement of the level measurement of both liquids can take place with a measuring system. Both liquid levels are independent of the density of the liquids. The ultrasonic sensor can be fastened to the separation container. Alternatively existing lines can be used for a standpipe for a new ultrasound measurement.

All measurements with well-known methods how:

-Density measurement

-Buoyancy transmitter for Level-Interface

can be replaced by the new patent of the measurement with ultrasonic.

Result: Increase of security, little costs, higher productivity!

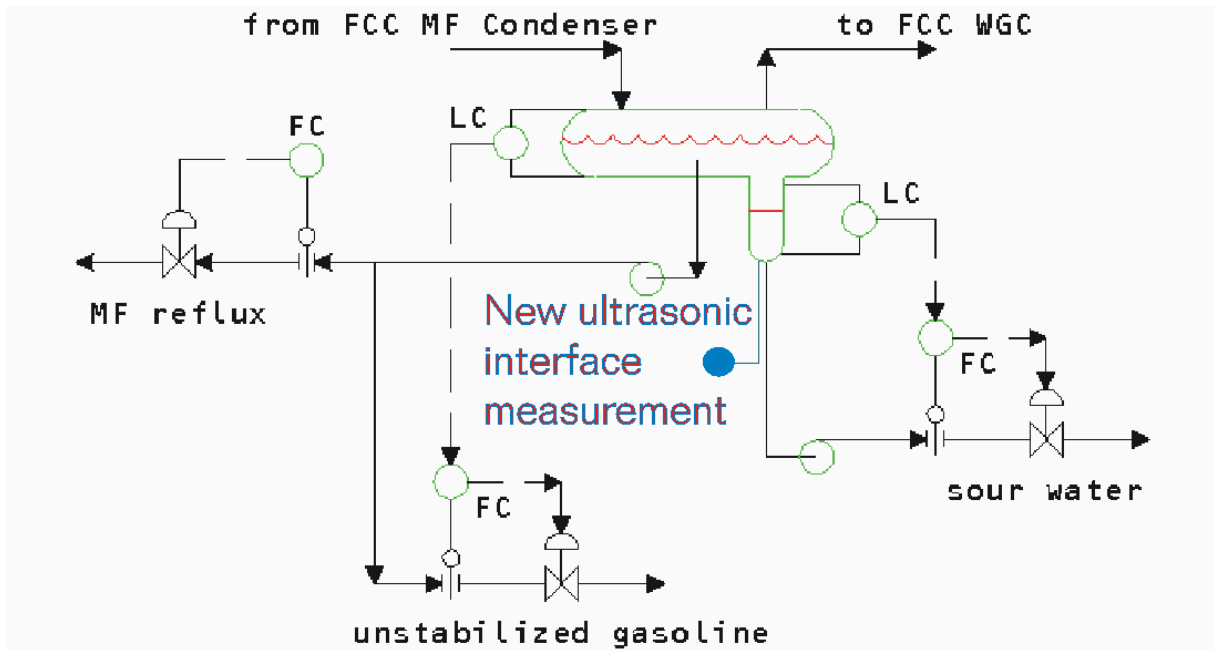

alternatively:

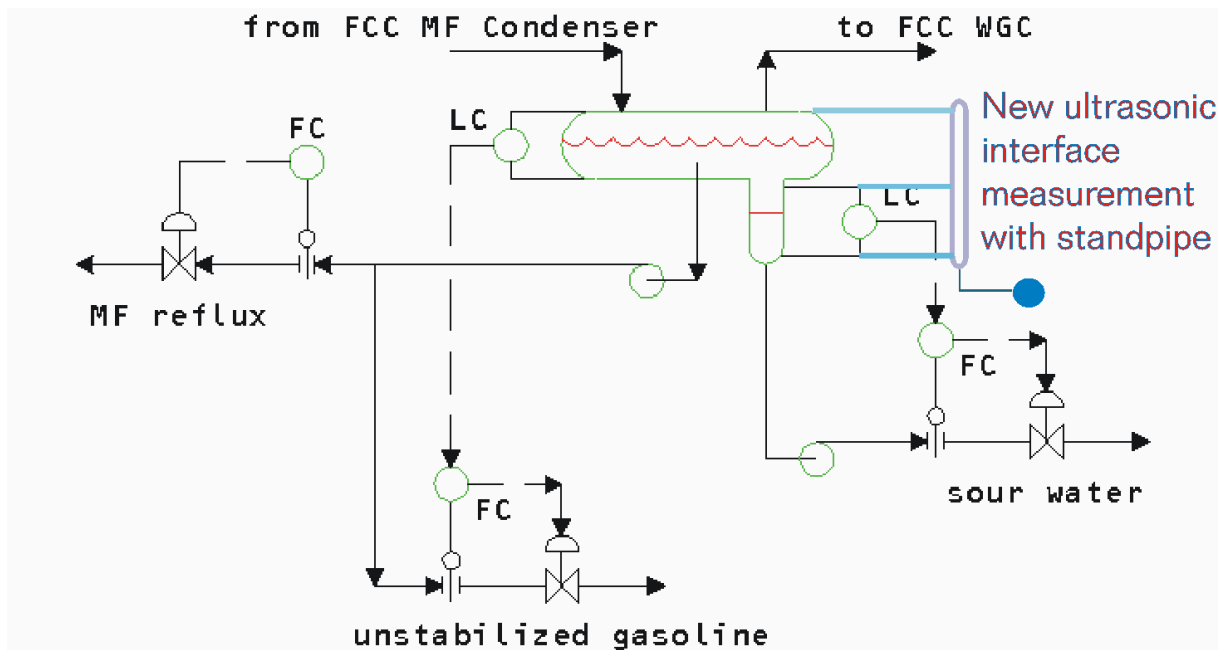

Potential applications at the example

As example a plant of Exxon is to serve here.

www.pacpl.com/product/PetroSpec/Lit_pspec/WRarticle.pdf

Here many new measurements can be inserted.

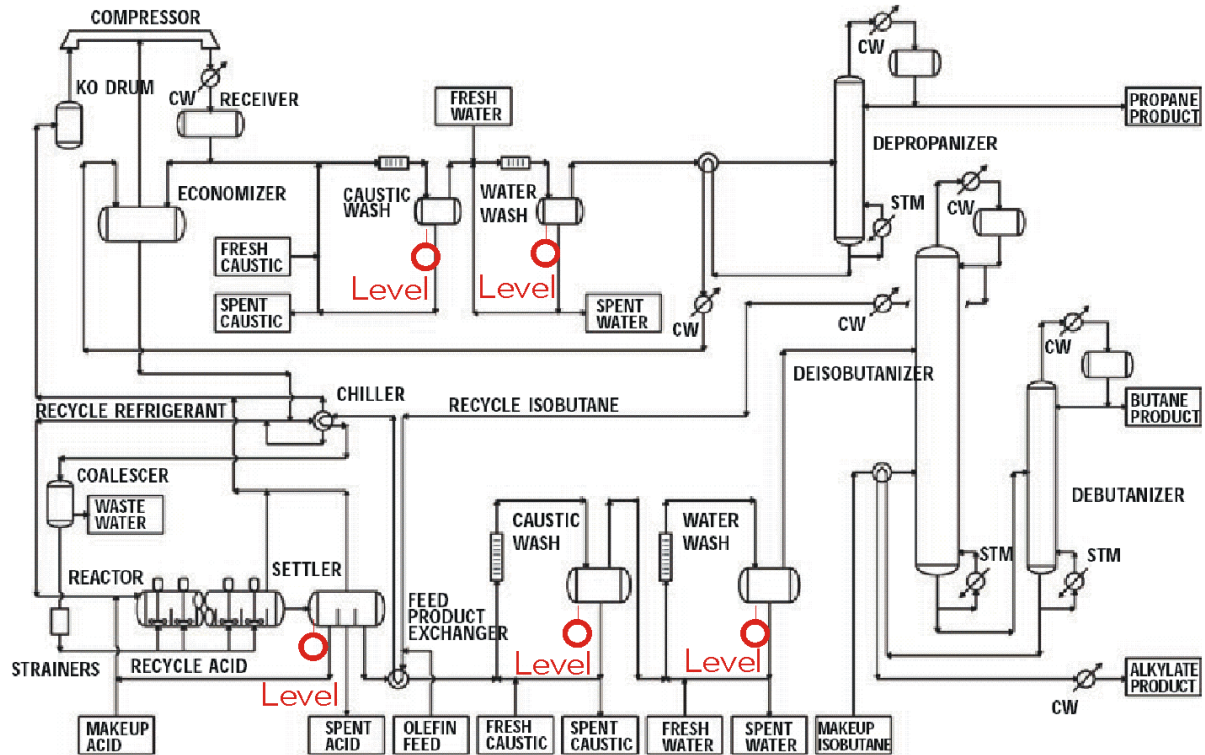

ExxonMobil stirred auto-refrigerated alkylation process

Used pictures:

Liquid Levels and Density
The Distillation Group Inc.
2001 Andrew W. Sloley.

Analyses&Technologies for the 21th Century
September 2002 Volume 12/No7
Steven Ackerman, Girish K. Chitnis & Davis S. McCaffrey JR.
ExxonMobil research and Engineering Co.

(announced to the patent DPMA) 103 25 953.8
Utility model application DPMA 203 08 928.6



Ingenieurbüro Jäger
Dipl.-Ing. (FH), Dipl.-Ing.Ök. Frank-Michael Jäger
Colkwitzer Weg 7
D - 04416 Markkleeberg
Tel.: 0341 33 80 172
E-Mail: Frank-Michael.Jaeger@t-online.de